

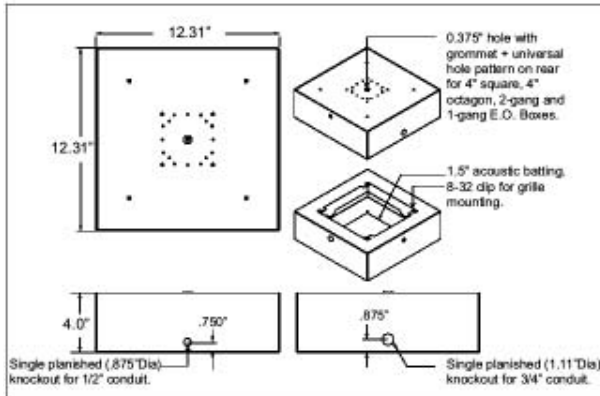

**CB84 Surface Back Box**

### Dimensions and Mounting



### ARCHITECTS' AND ENGINEERS' SPECIFICATIONS

The surface mount back box(es) shall be Alpha Communications®/Lowell CB84, or approved equal. Back box(es) shall be fabricated out of 20-gauge steel, with welded seams and finished in white powder coat paint finish. The rear of the back box(es) shall include provisions for mounting to a 4" square, 4" octagon, 2-gang or 1-gang electrical outlet box. It shall also include a .375" diameter hole with grommet in the rear for wire access. The sides shall have knockouts for 1/2" and 3/4" conduit. Back box(es) shall include 1.5" thick acoustic batting.

Contractor shall observe all local and national electrical and building codes.

## CB84 Surface Back Box

The Alpha Communications®/Lowell CB84 is an attractive surface mount back box for ceiling or wall installation of an 8" speaker or compatible (model# LUH-15T) paging horn, typically for schools, offices, medical facilities, restaurants, hotels, retail spaces, and correctional institutions.

The clean, square design is precision formed from 20-gauge steel. It features welded seams and 1/5" thick acoustic batting. The rear of the back box is punched with a universal mounting pattern for installing to a 4" square, 4" octagon, 2-gang, or 1-gang electrical outlet box. The rear also includes a .375" hole with grommet for protected wire access. Sides include planished knockouts for 1/2" and 3/4" conduit. The front features formed flanges with U-clips for secure screw mounting of companion speaker grille model IC105, JG-8X or vandal-resistant model SQLK-8L (order grilles separately). The back box measures 12.31" square x 4.0" deep and is finished in a durable white powder epoxy paint.

### FEATURES

- Surface mounts on wall or ceiling
- White, non-glare finish blends with ceiling materials
- Includes 1.5" thick acoustic batting
- Use with a variety of compatible speaker grilles
- Welded seams for a high quality finish and durability
- Universal mounting holes in rear
- Also accepts 1/2" and 3/4" conduits

### SPECIFICATIONS

**Dimensions:** Height: 12.31" (313mm)  
Width: 12.31" (313mm)  
Depth: 4.00" (102mm)

**Construction:** 20-gauge steel with welded seams

**Finish:** White powder coat epoxy paint

*Due to continuous product improvement, all colors, sizes, materials, finishes and specifications are subject to change without notice.*