



MIGHTY SLIM™

Model DO-001A

(2) Adjustable
Latch Screws

**ONLY
1.125"
DEEP!**



DO-001A Dimensions

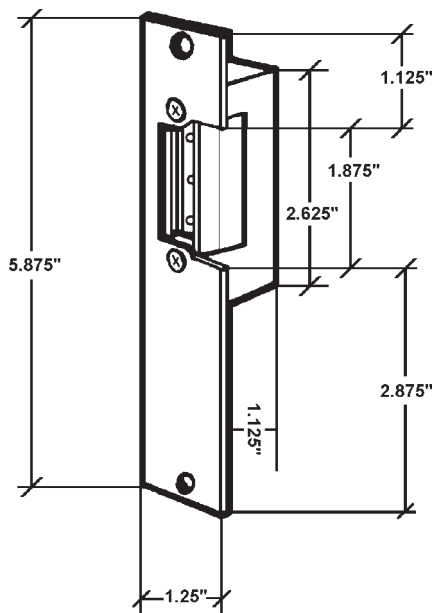

Copyright© 2002-2003, Alpha Communications®, All Rights Reserved

DO-001A Electric Door Strike Mortise Type - Reversible with Adjustable Latch

The Alpha Communications® DO-001A **MightySlim™** electric door strike is our lowest cost mortise type door strike. It is designed to be used primarily in wooden door frames. Under certain circumstances, the DO-001A can be used in hollow aluminum and hollow metal door frames.

The DO-001A **MightySlim™** can be used in right-handed or left-handed installations, simply by turning the door strike upside down, during installation.

When used with an 14-24VAC input, the DO-001A makes a buzzing sound, when activated. When used with a 14-24VDC input, the DO-001A activates silently.

Our unique screw-adjustable latch mechanism makes lock tongue alignment quick and easy. The ultra-slim 1.125" (28.5mm) deep body makes the DO-001A one of the easiest and quickest door strikes to install.

FEATURES

- Operates on 14-24VAC or 14-24VDC standard
- Buzzes on AC operation and is silent for DC operation
- Reversible for right-handed or left-handed installations
- Can be used with wooden or hollow metal door frames
- Requires only 1.125" deep door frame opening
- Has adjustable latch for easy tongue alignment
- Non fail-safe operation standard
- Positive Screw terminal connections
- Satin Grey Painted Steel Faceplate
- Very competitively priced - Our Lowest Cost Mortise type door strike
- 1 year limited factory warranty

Alpha Communications® carries a complete selection of electric door strikes for virtually any application. Please contact our sales dept. for more detailed information on this or on our other door strikes.

Due to continuous product improvement, all colors, sizes, materials, finishes and specifications are subject to change without notice.