

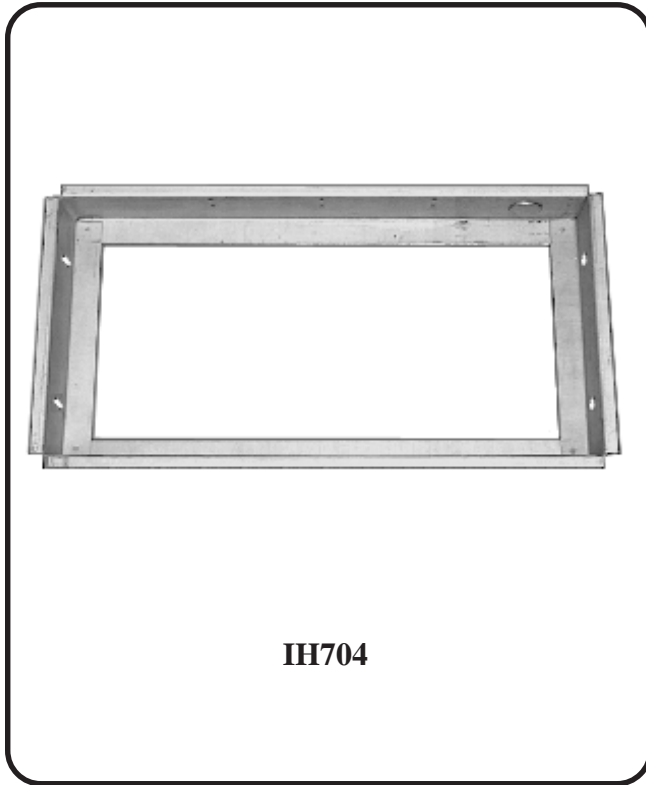

Product Specification Sheet



APS320
Rev. 1 - 03/2000



IH704 Flush Steel Backbox/Housing

The Alpha Communications® model IH704 is a flush mounting box/ring/housing, made of heavy gauge steel, in a galvanized finish.

It is used with the EK714W AM/FM music-intercom master station only.

Convenient knockouts on the top and bottom of the box, make it easy to attach to standard electrical EMT box connectors. The back is open to allow for equipment clearance and wiring as well.

SPECIFICATIONS

Dimensions: (wall opening required)
Height: 7.63" (194mm)
Width: 14.50" (369mm)
Depth: 2.00" (51mm)

ARCHITECTS' AND ENGINEERS' SPECIFICATIONS

The flush back box/ring/housing shall be Alpha Communications®/Tektone model IH704 or approved equal. It shall be made of heavy gauge steel, in a galvanized finish. It shall contain convenient electrical knockouts on the top and the bottom of the box, to attach to standard electrical EMT box connectors. It shall be used with the EK714W AM/FM music-intercom master station(s).

The IH704 shall be open in the back to allow for equipment clearance and wiring if needed.

Contractor shall observe all local and national electrical and building codes.

Due to continuous product improvement, all colors, sizes, materials, finishes and specifications are subject to change without notice.