

IH008

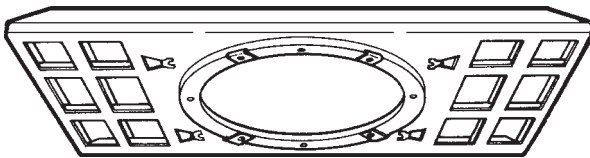

TB8X

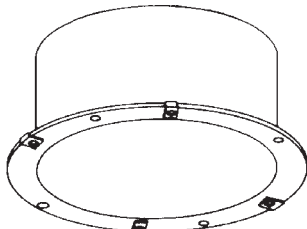

PH8-1

IH008 / PH8-1 / TB8X Ceiling Speaker Accessories

The Alpha Communications® IH008, PH8-1 and TB8X ceiling speaker accessories are designed to provide quick and secure mounting of the RB8S and RB8ST (series) ceiling speakers.

The **IH008** mounting ring is designed for mounting 8" (diameter) speakers in tile or sheetrock ceilings. They may be split and threaded into a 10.0" (diameter) hole. Ideal for suspended ceilings. It may be used with the optional PH8-1 protective enclosure.

The **TB8X** is made of Flamex (U.L. rated 94 V-O) flame retardant material and is designed for supporting speaker assemblies in Tee-Bar acoustical tile ceilings. The TB8X device places the weight on the Tee-Bars and supports the acoustical tile material when fully assembled. It may be used with the optional PH8-1 protective enclosure.

The **PH8-1** protective enclosure may be used with either the IH008 or TB8X devices. It is designed to totally enclose and protect the recessed side of the speaker. There is no metallic resonance, and it mutes sound above ceilings or in walls. In addition, there is a 1/2" conduit knockout in the top of the PH8-1. Ideal for acoustical tile or drywall ceiling installations.

Due to continuous product improvement, all colors, sizes, materials, finishes and specifications are subject to change without notice.

Ceiling Speaker Assembly (showing IH008 mounting)

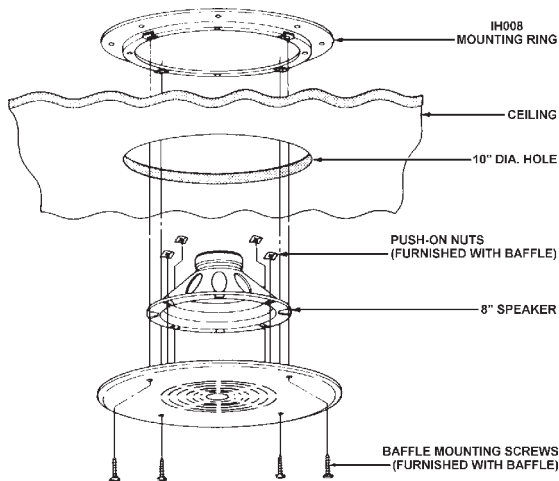

Ceiling Speaker Assembly (showing TB8X and PH8-1 mountings)

